



More Precision

wireSENSOR // Draw-wire displacement sensors



Industrial draw-wire sensors wireSENSOR P96 analog

Robust aluminum profile housing

Customer-specific designs

Potentiometer, current or voltage output

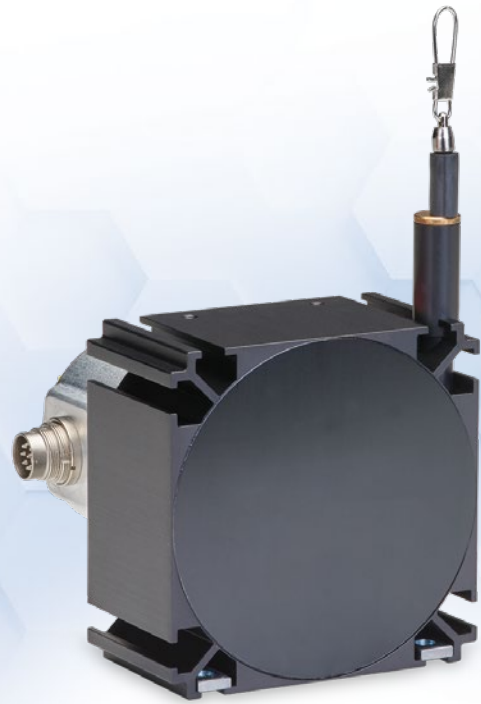

Output P

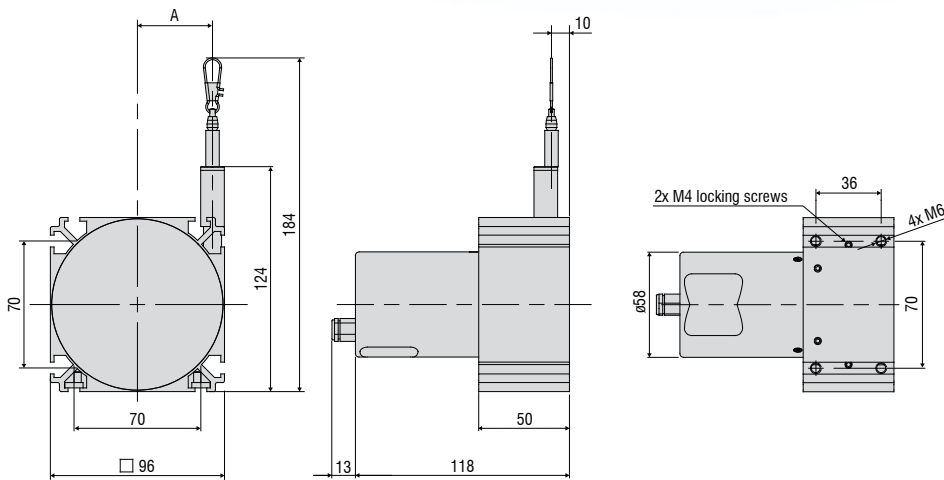

Output U/I

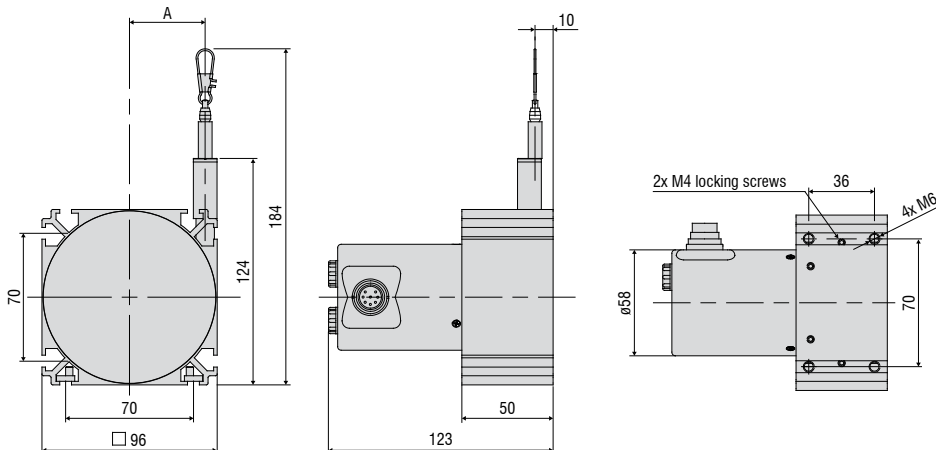

Measuring range (mm)	A (mm)
2000	approx. 32
2500	approx. 41.4

All dimensions in mm, not to scale

Model	WDS-2000-P96	WDS-2500-P96
Measuring range	2000 mm	2500 mm
Analog output ¹⁾	Potentiometer, current, voltage	
Resolution	towards infinity	
Linearity $\leq \pm 0.1\%$ FSO	$\leq \pm 2$ mm	$\leq \pm 2.5$ mm
Sensor element	Hybrid potentiometer	
Wire extension force (max.)	approx. 11 N	approx. 9 N
Wire retraction force (min.)	approx. 7.5 N	approx. 5.5 N
Wire acceleration (max.)	approx. 8 g	
Material	Housing	Aluminum
	Measuring wire	Polyamide-coated stainless steel (\varnothing 0.8 mm)
Wire mounting	Wire clip	
Mounting	Mounting grooves on the sensor housing	
Temperature range	Storage	-20 ... +80 °C
	Operation	-20 ... +80 °C
Connection	Potentiometer	integrated cable, axial, length 1 m
	Current, voltage	pluggable cable via 8-pin flange connector (DIN45326), radial
Shock (DIN EN 60068-2-27)	50 g / 10 ms in 3 axes, 1000 shocks each	
Vibration (DIN EN 60068-2-6)	20 g / 20 ... 2000 Hz in 3 axes, 10 cycles each	
Protection class (DIN EN 60529)	IP65 ²⁾	
Weight	approx. 1.1 kg	

FSO = Full Scale Output

¹⁾ Specifications for analog outputs from page 58 onwards.

²⁾ With plug version only when connected.

Article designation

WDS -	2000 -	P96 -	CA -	P
				Output type: P: potentiometer (with CA connection) U: voltage (with connection SR) I: current (with connection SR)
				Connection: SR: radial plug CA: integrated cable, axial, 1 m
				P96 series
				Measuring range in mm

Industrial draw-wire sensors

wireSENSOR P96 digital

Robust aluminum profile housing

Absolute or incremental encoder

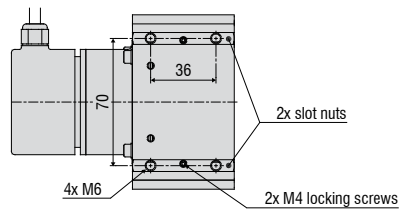
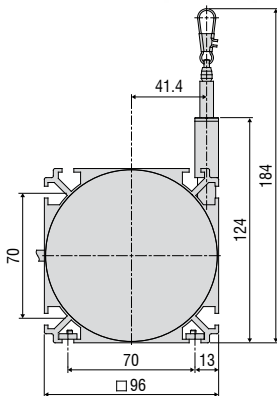
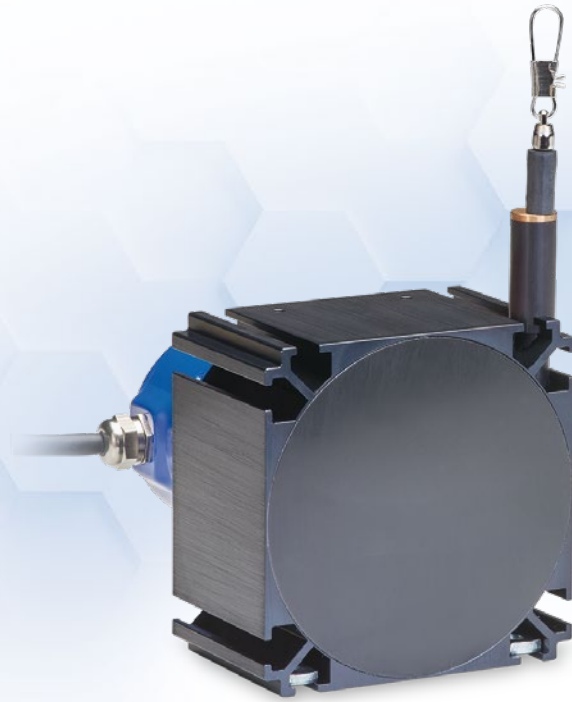

HTL/TTL output

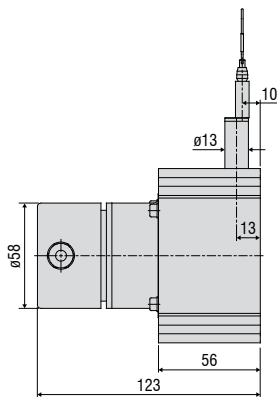

CO/PB/PN/ENIP/CAT output

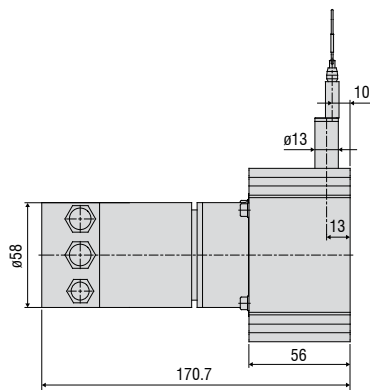

SSI output

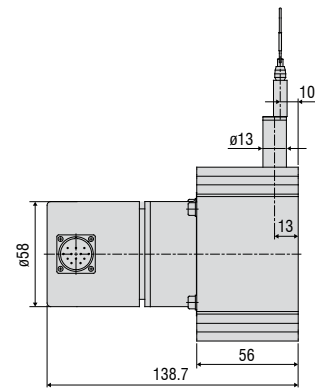

All dimensions in mm, not to scale

Model		WDS-3000-P96
Measuring range		3000 mm
Digital interface ¹⁾		PROFINET, Profibus DP, CANopen, EtherNet/IP, EtherCAT
Digital output ¹⁾		HTL, TTL, SSI
Resolution	HTL, TTL	0.087 mm (11.53 pulses/mm)
	SSI, PROFINET Profibus DP, CANopen, EtherNet/IP, EtherCAT	0.032 mm
Linearity		≤ ±0.02% FSO
Sensor element		Incremental/absolute encoder
Wire extension force (max.)		approx. 9 N
Wire retraction force (min.)		approx. 5.5 N
Wire acceleration (max.)		approx. 7 g
Material	Housing	Aluminum
	Measuring wire	Polyamide-coated stainless steel (ø 0.8 mm)
Wire mounting		Wire clip
Mounting		Mounting grooves on the sensor housing
Temperature range	Storage	-20 ... +80 °C
	Operation	-20 ... +80 °C
Connection	HTL, TTL	integrated cable, radial, length 1 m
	SSI	12-pin flange connector, radial
	PROFINET Profibus DP, CANopen, EtherNet/IP, EtherCAT	Bus cover
Shock (DIN EN 60068-2-27)		50 g / 10 ms in 3 axes, 1000 shocks each
Vibration (DIN EN 60068-2-6)		20 g / 20 ... 2000 Hz in 3 axes, 10 cycles each
Protection class (DIN EN 60529)		IP65 ²⁾
Weight		approx. 1.7 kg

FSO = Full Scale Output

¹⁾ Specifications for digital outputs from page 59 onwards.

²⁾ With plug version only when connected

Article designation

WDS -	3000 -	P96 -	CR -	TTL
				Output: HTL TTL CO: CANopen PB: Profibus DP SSI: Gray Code PN: PROFINET ENIP: EtherNet/IP CAT: EtherCAT
				Connection: SR (with SSI output): plug, radial CR (with HTL, TTL output): integrated cable, radial, 1 m BH (with CO, PB, PN, ENIP, CAT output): bus cover
				P96 series
				Measuring range in mm

Options

wireSENSOR

Customer-specific modifications for your series application

If the standard models do not meet certain specific requirements, draw-wire sensors from the standard range can be adapted accordingly by Micro-Epsilon. Cost-effective implementation can already be achieved with medium-sized quantities (depending on the type and number of changes).

Measuring wire

- Plastics
- Stainless steel (coated/uncoated)
- Different diameters
- Thicker wire for improved snap protection



Wire attachment

- Wire clip
- Eyelet
- Thread
- Wire extension

Connection/Output signal

- Different cable lengths
- Different plug variants
- Redundant sensor element
- Adaption of supply voltage
- Inverted signal
- Redundant signal outputs
- Alignment cable/connector outlet





- Sensor mounting**
- Mounting bracket
 - Mounting plate
 - Magnetic holder

- Wire guide**
- Wire wiper
 - Different designs of integrated deflection pulleys
 - Wire outlet socket from ceramics for increased diagonal pull up to 15°

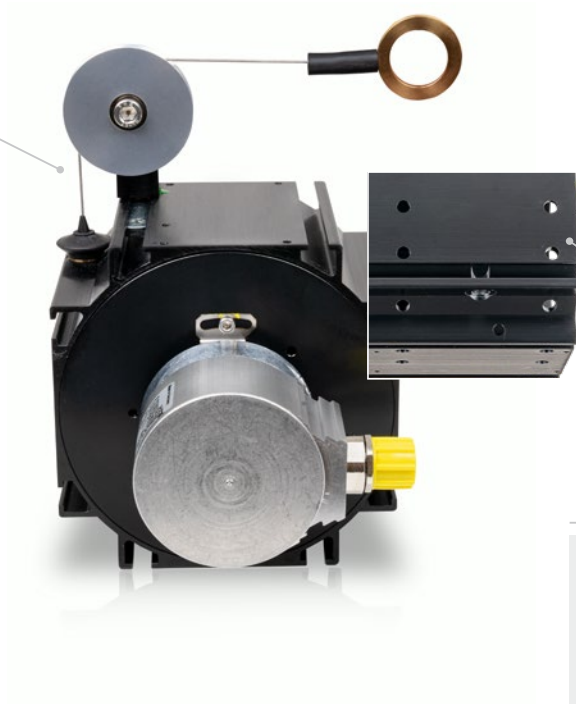

- Housing and environment**
- Wire outlet right (standard) / left
 - Protection class up to IP69K
 - Drainage holes
 - Stainless steel spring
 - Housing material
 - Wire acceleration
 - Snap protection

* Some options cannot be combined with each other; availability of options on request

Accessories

wireSENSOR

Wire deflection pulleys for external installation

TR1-WDS

Wire deflection pulley, adjustable, for sensors with a wire diameter ≤ 0.45 mm

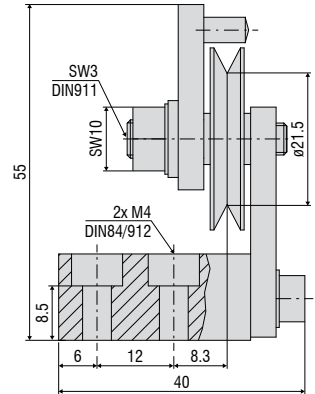
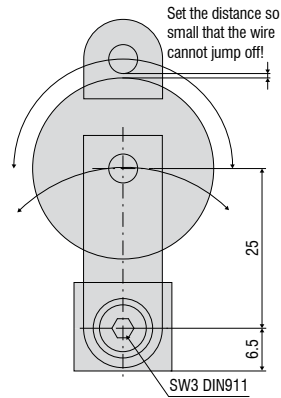

TR3-WDS

Wire deflection pulley, fixed, for sensors with a wire diameter ≤ 0.45 mm

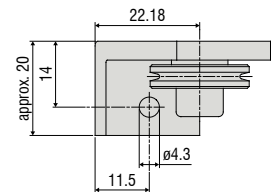
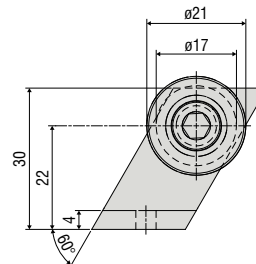

TR4-WDS

Wire deflection pulley, fixed, for sensors with a wire diameter of 0.8 mm to 1 mm

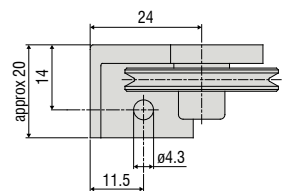
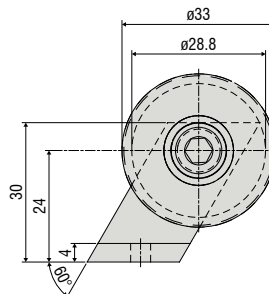

Wire deflection pulley for direct installation on the sensor housing

TR5-WDS

Integrated wire deflection pulley for P115 sensors with a wire diameter of 0.45 mm

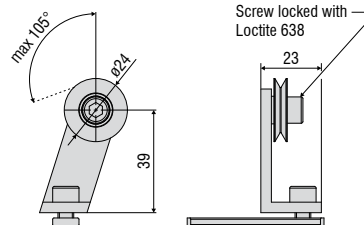

All dimensions in mm, not to scale

TR5-WDS(03)

Integrated double deflection pulley for P115 sensors with a wire diameter of 0.45 mm

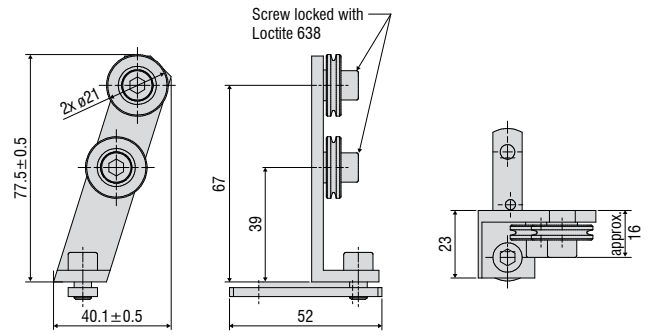

TR5-WDS(04)

Integrated double deflection pulley, 90° angled, for P115 sensors with a wire diameter of 0.45 mm

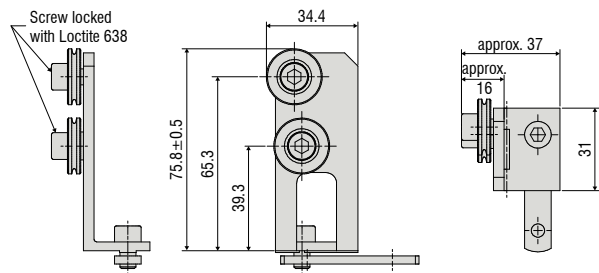

TR6-WDS(01)

Integrated wire deflection pulley for the P115 sensors with a wire diameter of 1 mm

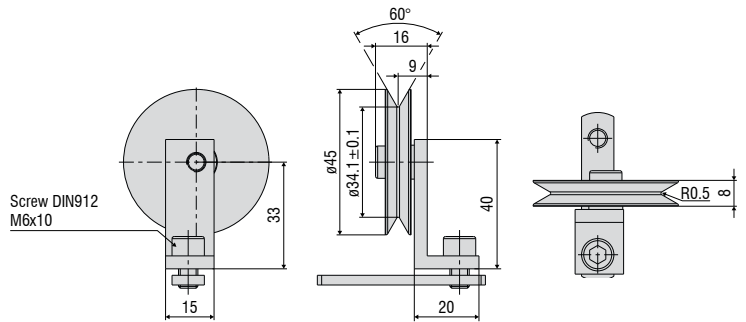

Mounting bracket set

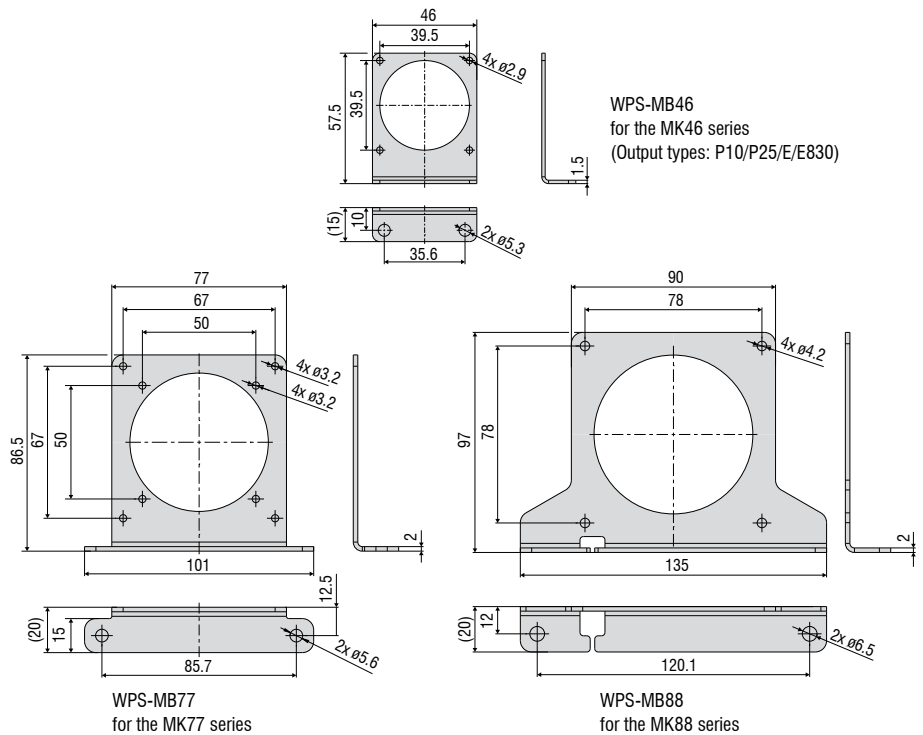

Accessories & Notes for installation

wireSENSOR

Accessories

WE-xxx-M4	Wire extension with M4 wire connection, x=wire length
WE-xxx-Clip	Wire extension with eyelet, x = wire length
WE-xxx-Clip-WSS	Wire extension with clip and uncoated wire d=0.45 mm
WE-xxx-Ring-PW	Wire extension with plastic ring and para-aramid wire, 1 mm
GK1-WDS	Fork head for M4
MH1-WDS	Magnetic holder for wire attachment
MH2-WDS	Magnetic holder for sensor mounting
MT-60-WDS	Mounting clamps for WDS-P60
FC8	Mating plug for WDS straight, 8-pin
FC8/90	Mating plug, 90° angled for WDS
PC3/8-WDS	Sensor cable, 3 m long, for WDS with 8-pin cable connector
WDS-MP60	Mounting plate for P60 models
WPS-MB46	Mounting bracket set for the MK46 series (output type: P10/P25/E/E830)
WPS-MB77	Mounting bracket set for the MK77 series
WPS-MB88	Mounting bracket set for the MK88 series
PC2/10-WDS-A	Cable for SSI encoder, 2 m long
PC10/10-WDS-A	Cable for SSI encoder, 10 m long
PC5/5-IWT	Sensor cable, 5 m long, M12x1 connector, 5-pin, A-coding

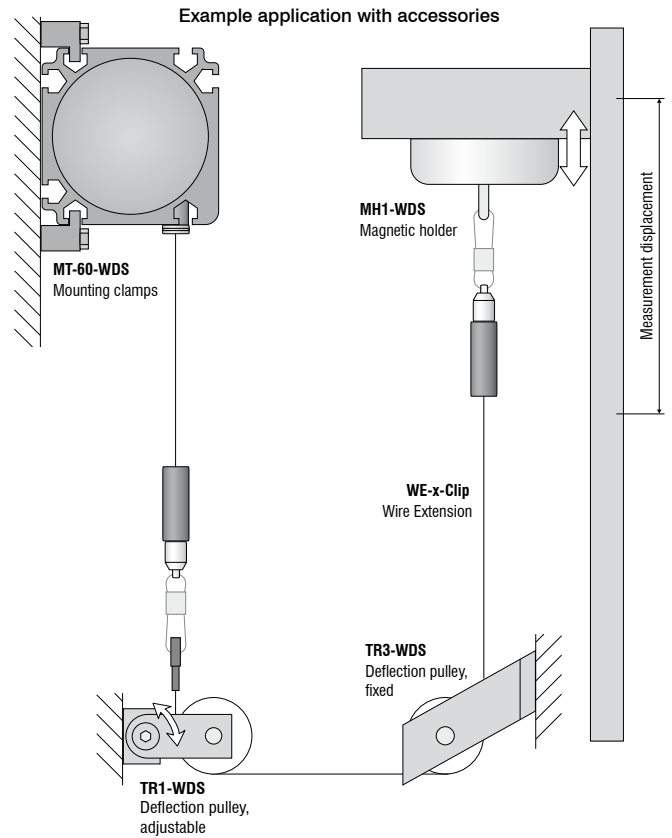

WDS-MP60

Mounting plate for P60 models

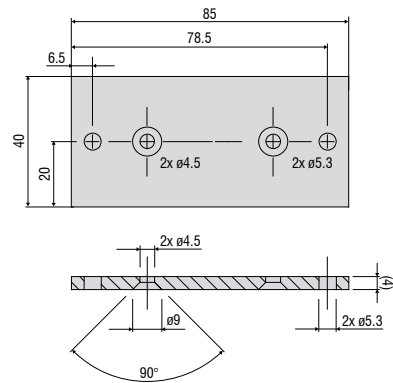

All dimensions in mm, not to scale

Installation instructions:

Wire attachment: during installation, do not allow at any time the measuring wire to freely return.

Angle of wire outlet: Make sure during installation that the wire outlet is straight (tolerance of $\pm 3^\circ$). Exceeding this tolerance leads to increased wear of the wire material and on the wire outlet.

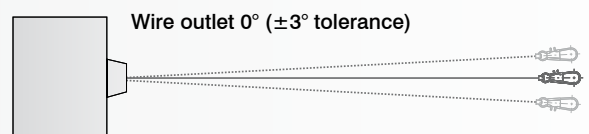

WE-xxxx-M4

Wire extension with M4 wire connection, x=wire length

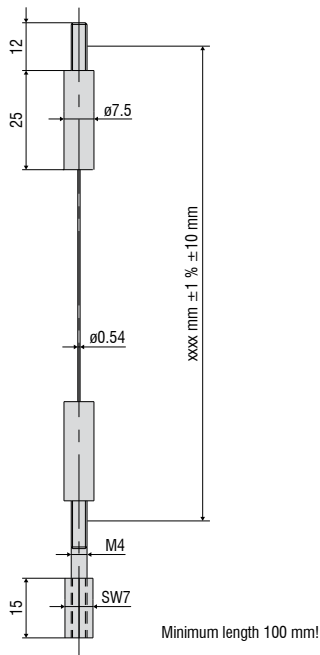

WE-xxxx-Clip

Wire extension with eyelet, x = wire length

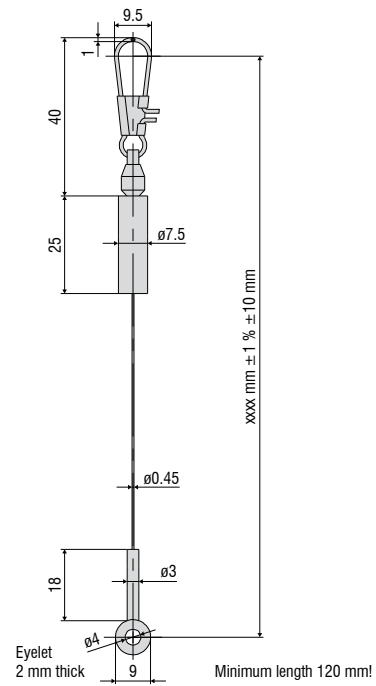

MH1-WDS

Magnetic holder for wire attachment

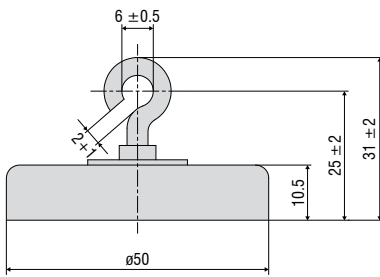

MH2-WDS

Magnetic holder for sensor mounting

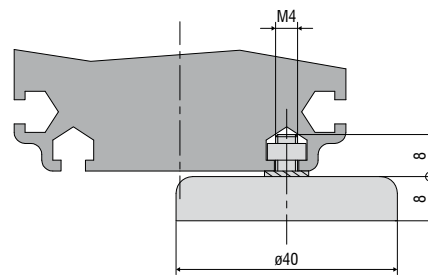

GK1-WDS

Fork head for M4

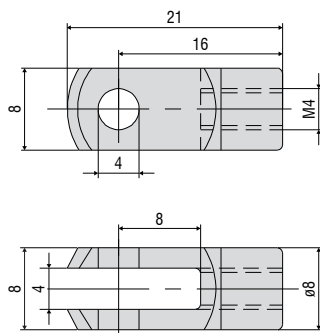

MT-60-WDS

Mounting clamps for WDS-P60

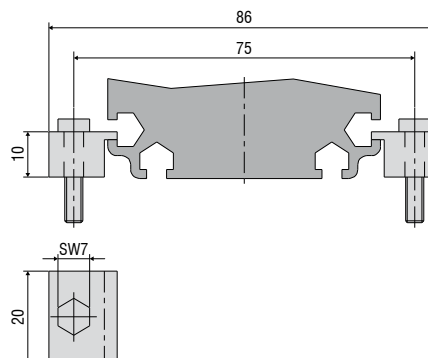

Output specifications

wireSENSOR

Analog

Output	Connector M16 -SA / -SR	Integrated cable -CA / -CR	Open contacts
Potentiometer output (P)			
Input voltage	max. 32 VDC with 1 kOhm / max. 1 W		
Resistance	1 kOhm $\pm 10\%$ (resistance divider)		
Temperature coefficient	$\pm 0.0025\%$ FSO/ $^{\circ}$ C		
	 <p>Sensor side</p> <p>1 = Input + 2 = Ground 3 = Signal</p>	<p>White = Input + Brown = Ground Green = Signal</p>	 <p>1 = Input + 2 = Signal 3 = Ground</p>
Voltage output (U)			
Supply voltage	14 ... 27 VDC (non-stabilized)		
Current consumption	max. 30 mA		
Output voltage	0 ... 10 VDC Option 0 ... 5 / ± 5 V		
Load resistance	>5 kOhm		
Output noise	0.5 mV _{eff}		
Temperature coefficient	$\pm 0.005\%$ FSO/ $^{\circ}$ C		
Electromagnetic compatibility (EMC)	EN 61000-6-4 EN 61000-6-2		
Adjustment range (if supported by the model)			
Zero	$\pm 20\%$ FSO	1 = Power supply 2 = Ground 3 = Signal 4 = Ground	White = Supply Brown = Ground Green = Signal Yellow = Ground
Sensitivity	$\pm 20\%$		
Current output (I)			
Supply voltage	14 ... 27 VDC (non-stabilized)		
Current consumption	max. 35 mA		
Output current	4 ... 20 mA		
Load	<600 Ohm		
Output noise	<1.6 μ A _{eff}		
Temperature coefficient	$\pm 0.01\%$ FSO/ $^{\circ}$ C		
Electromagnetic compatibility (EMC)	EN 61000-6-4 EN 61000-6-2		
Adjustment range (if supported by the model)			
Zero	$\pm 18\%$ FSO	1 = Power supply 2 = Ground	White = Supply Brown = Ground
Sensitivity	$\pm 15\%$		

CANopen

(for the MK88 and K100 series)

CANopen features	
Profiles	Communication profile CiA 301. Device profile CiA 406 (absolute linear encoder)
SDO	1x SDO server
PDO	2x TxPDO
PDO modes	Event/time-triggered, synchronous (cyclic/acyclic)
Preset value	The "Preset" parameter can be used to set the current measured value to any value. The difference from the original value is stored in the object.
Direction	Via the operating parameter, the counting direction of the measured values can be reversed
Diagnosis	Heartbeat, Emergency Message
Default setting	AutoBaud(9), Node-ID 1

Setting the baud rate	
Baud rate adjustable via LSS or object 0x3001	
0	1000 kBaud
2	500 kBaud
3	250 kBaud
4	125 kBaud
6	50 kBaud
9	AutoBaud (default)

Description of the connections	
Pin	Assignment
1	n. c.
2	V+ (7...32VDC)
3	GND
4	CAN-High
5	CAN-Low



Setting the subscriber address (node ID)
Address adjustable via LSS or object 0x3000 (1....127, 1 = default)

Output specifications

wireSENSOR

CANopen

(for P60, P96, P115 and P200 series)

CANopen features	
Bus protocol	CANopen
Device profile	CANopen - CiA DSP 406, V 3.0
CANopen features	Device class 2, CAN 2.0B
Operating modes (with SDO progr.)	<p>Polling mode (asynch, via SDO)</p> <p>Cyclic mode (asynch-cyclic). The encoder cyclically transmits the current actual process value without a request by a master. The cycle time can be parameterized for values between 1 and 65,535 ms.</p> <p>Synch mode (synch-cyclic). The encoder transmits the current actual process value after receiving a synch telegram sent by a master. The synch counter in the encoder can be parameterized such that the position value is transmitted only after a defined number of synch telegrams.</p> <p>Acyclic mode (synch-acyclic)</p>
Preset value	With the "Preset" parameter the encoder can be set to a desired actual process value that corresponds to the defined axis position of the system. The offset value between the encoder zero point and the mechanical zero point of the system is saved in the encoder.
Rotary direction	With the operating parameter the rotary direction in which the output code is to increase or decrease can be parameterized.
Scaling	The steps per rotation and the total revolution can be parameterized.
Diagnosis	The encoder supports the following error messages: - Position and parameter errors - Lithium cell voltage at lower limit value (multi-turn)
Default setting	50 kbit/s, node number 1

Baud rate	DIP switch setting		
	1	2	3
10 kBit/s	OFF	OFF	OFF
20 kBit/s	OFF	OFF	ON
50 kBit/s	OFF	ON	OFF
125 kBit/s	OFF	ON	ON
250 kBit/s	ON	OFF	OFF
500 kBit/s	ON	OFF	ON
800 kBit/s	ON	ON	OFF
1 MBit/s	ON	ON	ON

Description of the CANopen connections	
CAN_L	CAN bus signal (dominant Low)
CAN_H	CAN bus signal (dominant High)
V+	Supply voltage 10 ... 30 VDC
GND	Ground connection for V+

(Terminals with the same designation are internally interconnected)

Settings of the CANopen participant address
Address can be set with rotary switch. Example: Participant address 23

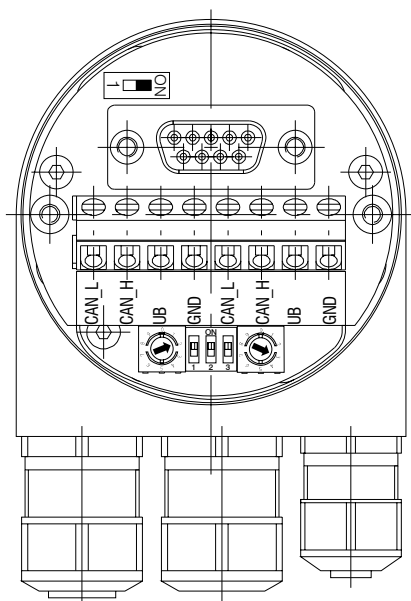
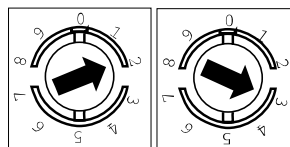

Setting of the terminating resistor CANopen



ON = Last participant
 OFF = Participant X

SSI (Gray Code)

Connections	
1 V+	Supply connection of rotary encoder
2 GND	Ground connection of rotary encoder The voltage drawn to GND is V+
3 Pulses +	Positive SSI clock input. Pulse + forms a current loop with Pulse -. A current of approx. 7 mA in direction of Pulse + input generates a logical 1 in positive logic.
4 data +	Positive, serial data output of the differential line driver. A high level at the output corresponds to logical 1 in positive logic.
5 ZERO	Zero-setting input for setting a zero point at any point within the total resolution. The zeroing process is triggered by a High pulse (pulse duration ≥ 100 ms) and must take place after the rotating direction selection (F/R). For maximum interference immunity, the input must be connected to GND after zeroing.
6 Data -	Negative, serial data output of the differential line driver. A high level at the output corresponds to logical 0 in positive logic.
7 Pulses -	Negative SSI clock input. Pulse - forms a current loop with Pulse +. A current of approx. 7 mA in direction of the clock input generates a logical 0 in positive logic.
8 / 10 $\overline{\text{DATAVALID}}$ $\overline{\text{DATAVALID}}$ MT	Diagnosis outputs DV and DV MT Jumps in data word, e.g., due to defective LED or photo receiver, are displayed via the DV output. In addition, the power supply of the multi-turn sensor unit is monitored and the DV MT output is set when the voltage falls below a specified level. Both outputs are low-active, i.e. are switched through to GND in the event of an error.
9 F/R	Forward/reverse counting direction input. When not connected, this input is on High. F/R High means increasing output data with a clockwise rotating shaft when looking at the flange. F/R Low means increasing values with a counterclockwise rotating shaft when looking at the flange.
11 / 12	Not assigned

Pin assignment		
Connector	Cable color	Assignment
1	brown	V+
2	black	GND
3	blue	Pulse +
4	beige	Data +
5	green	ZERO
6	yellow	Data -
7	purple	Pulse -
8	brown-yellow	$\overline{\text{DATAVALID}}$
9	pink	F/R
10	black-yellow	$\overline{\text{DATAVALID}}$ MT
11	-	-
12	-	-

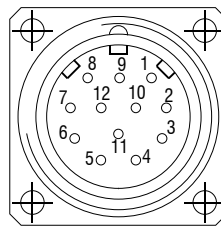

Use twisted-pair cables as extension cables.

Inputs	
Control signals $\overline{\text{F/R}}$ and zero	
High level	$> 0.7 \text{ V+}$
Low level	$< 0.3 \text{ V+}$
Circuitry	$\overline{\text{F/R}}$ input with 10 kOhm against V+, Zero-setting input with 10 kOhm against GND.
SSI clock	
Optocoupler inputs for galvanic isolation	

Outputs		
SSI data	RS485 driver	
Diagnosis outputs		
Push-pull outputs, short circuit proof		
High level	$> \text{V+} - 3.5 \text{ V}$	(with $I = -20 \text{ mA}$)
Low level	$\leq 0.5 \text{ V}$	(with $I = 20 \text{ mA}$)

Output specifications

wireSENSOR

PROFIBUS

Profibus DP features	
Bus protocol	Profibus DP
Profibus features	Device class 1 and 2
Data Exch. Functions	Input: Position value Additional configurable speed signal (output of the current rotary speed) Output: Preset value
Preset value	With the "Preset" parameter the encoder can be set to a desired actual value that corresponds to the defined axis position of the system.
Parameter functions	Rotary direction: With the operating parameter the rotary direction for which the output code is to increase or decrease can be parameterized. Scaling: The steps per rotation and the total revolution can be parameterized.
Diagnosis	The encoder supports the following error messages: - Position error - Lithium cell voltage at lower limit value (multi-turn)
Default setting	Participant address 00

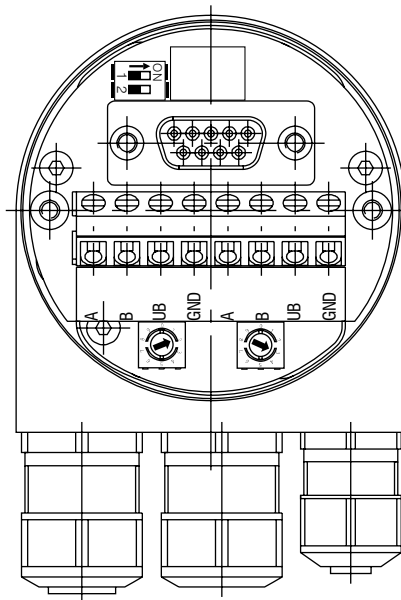

Setting of the terminating resistor Profibus DP



ON = Last participant
OFF = Participant X

Settings of the Profibus participant address

Address can be set with rotary switch. Example: Participant address 23

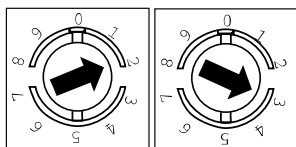

Profibus DP connections

A Negative serial data line

B Positive serial data line

V+ supply voltage 10 ... 30 VDC

GND ground connection for V+

(Terminals with the same designation are internally interconnected)

PROFINET

PROFINET features	
Bus protocol	PROFINET
Device profile	Encoder profile PNO 3.162 Version 4.1
Features	<ul style="list-style-type: none"> - 100 MBaud Fast Ethernet - Automatic address assignment - Real-time (RT) Class 1, IRT Class 2, IRT Class 3
Process data	<ul style="list-style-type: none"> - Position value 32-Bit input data with/without rotational speed 16/32 Bit - Telegram 81-83 of the Profidrive profile

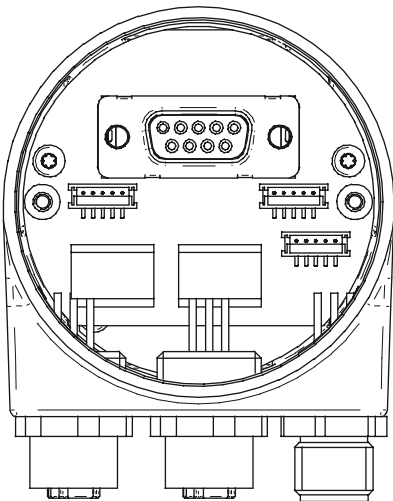

Pin assignment		
Supply voltage		
Connector	Connection	Description
Pin 1	V+	Supply voltage
Pin 2	N.C.	Not assigned
Pin 3	GND	Ground connection
Pin 4	N.C.	Not assigned

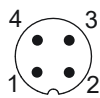

1x M12 connector (pin), A-coded

PROFINET (data line)		
Connector	Connection	Description
Pin 1	TxD+	Transmitted data+
Pin 2	RxD+	Received data+
Pin 3	TxD-	Transmitted data-
Pin 4	RxD-	Received data-

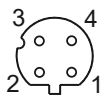

1x M12 connector (pin), A-coded

Output specifications

wireSENSOR

EtherNet/IP

Characteristics - EtherNet/IP	
Bus protocol	EtherNet/IP
Device profile	Encoder Device, Type22hex, according to CIP specification
Features	<ul style="list-style-type: none"> - 100 MBaud Fast Ethernet - Programmable IP address - Automatic IP address assignment (DHCP) - Direction of rotation, resolution, total resolution and preset programmable according to CIP specification
Process data	Position value, warning flag, alert flag Assembly Instances 1 and 2 according to CIP specification

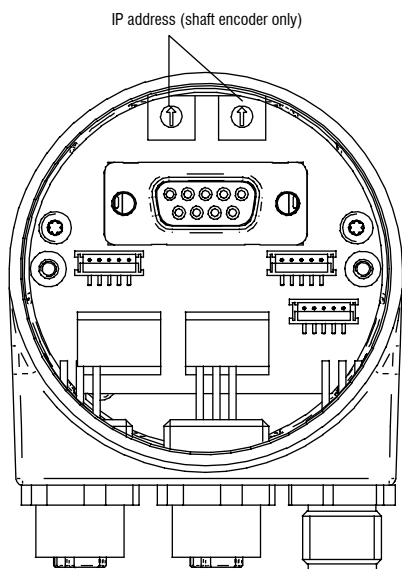

Pin assignment		
Supply voltage		
Connector	Connection	Description
Pin 1	UB	Supply voltage
Pin 2	N.C.	Not assigned
Pin 3	GND	Ground connection
Pin 4	N.C.	Not assigned

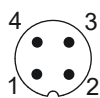

1x M12 connector (pin), A-coded

EtherNet/IP (data line)		
Connector	Connection	Description
Pin 1	TxD+	Transmitted data+
Pin 2	RxD+	Received data+
Pin 3	TxD-	Transmitted data-
Pin 4	RxD-	Received data-

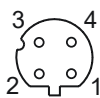

2x M12 connectors (socket), D-coded

IP address

Adjustable via HEX rotary switch. Example: IP address B5_{hex}
Configuration via DHCP: 00hex

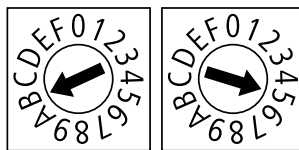

EtherCAT

Characteristics - EtherCAT

Bus protocol	EtherCAT
Device profile	CoE (CANopen over EtherCAT) DSP406
Features	<ul style="list-style-type: none"> - 100 Mbaud Ethernet - Automatic address assignment - Distributed-Clock for precise synchronization. Device can be configured as „Reference Clock“ - Default 10 byte PDO, configurable - 4 byte PDO / 2 byte PDO for shorter cycle times
Process data	Position value Warnings System time
Cycle times	Depending on sensor type, activated scaling function and PDO length. Min. cycle time: 62.5 μ s
Synchronization	0x00 Free Run, not synchronized 0x03 Distributed clocks DC, synchronized with SYNC0/SYNC1 event

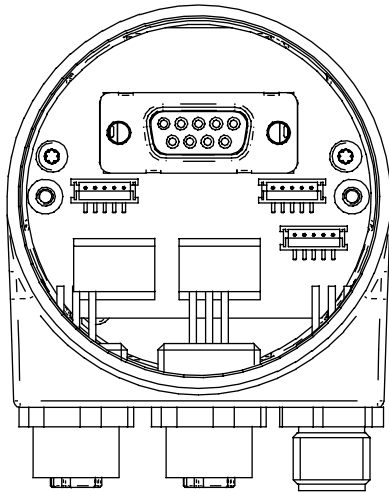

Pin assignment

Supply voltage

Connector	Connection	Description
Pin 1	UB	Supply voltage
Pin 2	N.C.	Not assigned
Pin 3	GND	Ground connection
Pin 4	N.C.	Not assigned



1x M12 connector (pin), A-coded

EtherCAT (data line)

Connector	Connection	Description
Pin 1	TxD+	Transmitted data+
Pin 2	RxD+	Received data+
Pin 3	TxD-	Transmitted data-
Pin 4	RxD-	Received data-



2x M12 connectors (socket), D-coded

Incremental encoder

Output signals

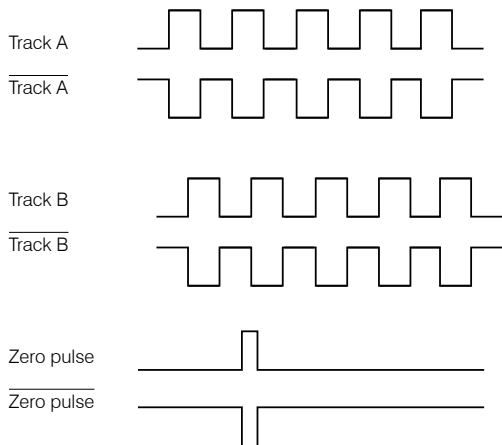

TTL Output	Line driver (5 VDC)	
High level	$\geq 2.5 \text{ V}$	(with $I = -20 \text{ mA}$)
Low level	$\leq 0.5 \text{ V}$	(with $I = 20 \text{ mA}$)
High load	$\leq 20 \text{ mA}$	
Tracks	A, \bar{A} , B, \bar{B} , 0	

Output TTL01/ TTL02	NPN (5 VDC $\pm 5 \%$)	
High level	$> 4.5 \text{ V}$	
Low level	$< 1.0 \text{ V}$	
High load	$\leq 3 \text{ mA}$	
Tracks (TTL01)	A, B, 0	
Tracks (TTL02)	A, \bar{A} , B, \bar{B} , 0	

Output HTL	Push-pull (10 ... 30 VDC)	
High level	$\geq V+ -3 \text{ V}$	(with $I = -20 \text{ mA}$)
Low level	$\leq 1.5 \text{ V}$	(with $I = 20 \text{ mA}$)
High load	$\leq 40 \text{ mA}$	
Tracks	A, \bar{A} , B, \bar{B} , 0	

Output E	Push-pull (5 VDC)	
High level	$\geq V+ -2.5 \text{ V}$	
Low level	$\leq 0.5 \text{ V}$	
High load	$\leq 50 \text{ mA}$	
Tracks	A, B, 0	

Output E830	Push-pull (8 ... 30 VDC)	
High level	$\geq V+ -3 \text{ V}$	
Low level	$\leq 2.5 \text{ V}$	
High load	$\leq 50 \text{ mA}$	
Tracks	A, B, 0	

Pin assignment TTL, HTL		
Connector	Cable color	Assignment
Pin 1	pink	Track B inv.
Pin 2	blue	V+ Sense
Pin 3	red	Track N (zero pulse)
Pin 4	black	Track N inv. (zero pulse inv.)
Pin 5	brown	Track A
Pin 6	green	Track inv.
Pin 7	-	-
Pin 8	gray	Track B
Pin 9	-	-
Pin 10	white-green	GND
Pin 11	white	GND Sense
Pin 12	brown-green	V+

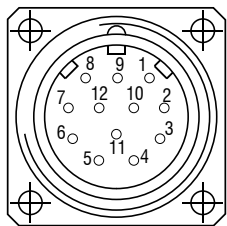

V+ Sense and GND Sense are directly connected to V+ or GND. Recommendation: Use twisted-pair cables (e.g. A/A inv.) from a cable length of 10 m.

Pin assignment E, E830	
Cable color	Assignment
white	0 V
brown	V+
green	A
-	\bar{A}
yellow	B
-	\bar{B}
gray	0

Pin assignment TTL01	
Cable color	Assignment
brown	0 V
gray	V+
white	A
green	B
yellow	0

Pin assignment TTL02	
Cable color	Assignment
red	V+
black	0 V
brown	A
black	\bar{A}
orange	B
black	\bar{B}
yellow	0
black	n. c.

Sensors and Systems from Micro-Epsilon



Sensors and systems for displacement, distance and position



Sensors and measurement devices for non-contact temperature measurement



Measuring and inspection systems for metal strips, plastics and rubber



Optical micrometers and fiber optics, measuring and test amplifiers



Color recognition sensors, LED analyzers and inline color spectrometers



3D measurement technology for dimensional testing and surface inspection